



TABLE OF CONTENTS

A. Introduction	1
B. About the LEIT 4000 Controller	1
C. Technical Assistance	1
D. Copyright and Compliance	1
E. Features	1
1. System	2
1.1 Models available	2
1.2 Parts identification	2
1.3 USB updater	2
1.4 Required system components	3
1.5 Tools and supply requirements	4
2. Installation	4
2.1 Valve installation model 170S-XXX (2-WAY)	4
2.2 LEMA Solenoid actuator installation model 1700S (2-WAY)	4
2.3 Wire installation and distance	5
2.4 Controller installation	5
3. Sensor installation	5
3.1 Sensor connection to unused station	6
3.2 Sensor connection if station is not available	6
3.3 Compatible sensors	7
4. Pump or any electrical equipment installation	7
4.1 RKIT installation to the MV/Pump terminal	7
4.2 RKIT installation to one of the valve station terminal connectors	7
5. Programming	10
5.1 Manual run	11
5.2 Rain stop/restart	12
5.3 Monthly budget	13
5.4 Check status	13
5.5 Setup schedule	14
5.6 Setup system	16
6. Troubleshooting	19
6.1 LEIT key	19
6.2 LEIT controller	19
6.3 LEMA solenoid actuator	19
6.4 Hydraulic valves	20
6.5 Field control wires	20
7. Warranty	21
8. LEIT control programming quick reference chart	22
9. USB Updater	24

A. INTRODUCTION

Thank you for purchasing a DIG LEIT® 4000 series controller.

This manual describes how to get the LEIT 4000 controller up and running quickly. After reading this manual and having been familiarized with the basic functionality of the controller, the manual can be used as a reference for less common tasks in the future.

Please take the time to read through the enclosed instructions and follow them step-by-step.

B. ABOUT THE LEIT 4000 CONTROLLER

The LEIT 4000 Series Controller is an advanced ambient light powered water management irrigation controller that uses a time tested photovoltaic module which harnesses light energy to generate electricity that is stored and used to power the controller day and night in any kind of weather.

DIG LEIT irrigation controllers are available in two other models: LEIT X (without radio) or LEIT XRC (with radio control capability).

The LEIT 4000 irrigation controller has an improved menu base with straightforward programming that allows for a wide range of irrigation programs. Features include four programs with three start times per valve, manual runs (both temporary or stored), rain delays for up to 99 days, budgeting up to 200 percent, status checks, history reports, program setting modification, and more.

C. TECHNICAL ASSISTANCE

Should you encounter any problem(s) with this product or if you do not understand its many features, please refer to this operating manual first. If further assistance is required, DIG offers the following customer support:

Technical Service USA

- DIG's Technical Service Team is available to answer questions from 8:00 AM to 5:00 PM (PST) Monday-Friday (except holidays) at 800-322-9146.
- Questions can be emailed to questions@digcorp.com or faxed to 760-727-0282.
- Specification documents and manuals are available for download at www.digcorp.com.

Customer Assistance Outside the USA

Contact your local distributor.

D. COPYRIGHT AND COMPLIANCE

Copyright 2025 DIG Corporation. All rights reserved. LEIT is registered trademark. LEIT 4000, LEIT X & XRC, and LEIT Multi-Pro Handset are each trademarks of DIG Corporation.

Patent #: 5,229,649 and 5,661,349

FCC, CE, Canada and Australia compliance

Warning: The user should make no field changes or modifications to the LEIT 4000 controller.

All adjustments and changes must be made at DIG's facility under the specific guidelines set forth in our manufacturing process. Any change or modification to the equipment will void the users authority to operate the unit, and render the equipment in violation of FCC part 15 subpart C, 15.247.

Any tampering with this product will void the warranty.

E. FEATURES

- Operates 4-8 stations and a master valve or pump start without AC power hookup, batteries or conventional solar panels
- Software in English, Spanish, Italian or French
- 4 programs with 3 start times per program
- Budgeting feature for a yearly watering schedule can be set by month
 - Increase or decrease irrigation from 10-200% in 10% increments
- Review status and history reports
- Built to the highest quality control standard (ISO 9002)
 - Controller functions and operations are 100% tested
 - Controller waterproofing is 100% tested

- Non-volatile memory holds programs indefinitely without batteries
- All power is provided by an internal photovoltaic module and microelectronic energy management system fueled by ambient light
 - Functions day or night in all weather conditions and in most outdoor locations
- 365 day calendar with leap year
- Assign-rain, moisture or freeze sensors to an individual valve or to the entire system using SKIT 8821-4 connector
- Manual watering by station or program
- Environmentally friendly - uses clean power
 - No batteries or AC power needed

1. SYSTEM

This chapter explains the components and installation of the LEIT 4000 controller. The LEIT controller must be installed according to the manufacturer's recommendations; failure to do so will void the manufacturer's warranty. The LEIT 4000 can operate with all discontinued solenoids, such as LEMA 1500-4 and 1500S. DIG recommends all new installations be done using the 160HE series valves and 1600HE solenoid actuator.

1.1 Models Available

- 1.1 The LEIT 4000 irrigation controller is available in three models:
 - LEIT 4004 4 stations plus MV/Pump
 - LEIT 4006 6 stations plus MV/Pump
 - LEIT 4008 8 stations including MV/Pump
- 1.2 If you have purchased a LEIT 4004 or 4006, you have the option of connecting an additional master valve to your controllers.
- 1.3 If you have purchased a LEIT 4008, you have the option to configure station 8 as a master valve when you install a master valve on your system.
- 1.4 All LEIT 4000 series controllers are fitted with a wiring connector strip that has a maximum of 8 connector ports for hot wires (stations) and 2 connector ports for common wires.

1.2 Parts Identification

- 1 PVM – Photovoltaic module harnesses light energy and uses it to generate electricity to power the unit day and night in any kind of weather condition.
 - 2 LCD Display – Displays the application stored in the controller.
 - 3 Programming Buttons – Use these 4 buttons to program, modify and review the status of a LEIT 4000 controller.
 - 4 Location to insert the LEIT Key – To begin, insert the LEIT Key to enter the LEIT controller's programming screens (use 1, 9-volt battery). The LEIT Key is not included.
 - 5 Terminal Strip – Up to 11 terminals are available, depending on model, to connect the valves wires, sensors via the SKIT and the MV/P.
 - 6 USB Connection – for software updates.
- LEIT Door and key – To enter the controller use the key (included) to unlock the door and remove it.

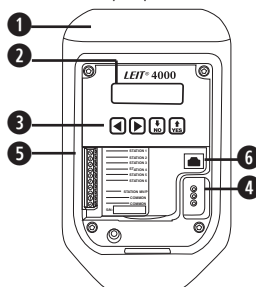

1.3 USB Updater

The LEIT 4000 is now supplied with a convenient USB port in order to keep the controller up to date with new software versions.

If you have a laptop that is running Windows 7 you will be able to make updates in the field without removing the controller from the pole. If your computer is running Windows Vista, XP or 2000 you will need to remove your LEIT 4000 and bring it to a computer that has a viable internet connection. Please note that if you are removing the controller, be sure all valve wires are marked clearly to simplify re-installation.

*At this time Apple OSX is not supported.

Step 1 With a computer that has a viable internet connection, download the LEIT 4000 USB Updater.zip file from www.digcorp.com/LEIT-4000-software-update.

- Step 2** After the file has completed downloading, unzip it by double clicking on file.
- Step 3** Next plug the USB type B into the LEIT 4000 and the USB type A into your computer. If running Windows 7, please skip to step 5.
- Step 4** For computers running Windows Vista, XP or 2000, the computer auto-detects that a device has been connected and will ask you to install the proper drivers in order to establish a connection with the LEIT 4000 controller. Once the necessary drivers have been installed, proceed to the next step.
- Step 5** Open up the unzipped 4000 USB Updater folder and double-click to run the LEIT 4000 USB Updater 1XX.exe file.
- Step 6** Follow all instructions on screen to complete the update process of your LEIT 4000 controller.
- If you have any questions please call us at 1-800-322-9146 or 760-727-0914.

1.4 Required System Components

To properly install the LEIT controller, the following components will be needed:

- Control unit: LEIT series controllers programmed with bilingual software versions SW Ver 1.23 and later EE Ver 1.02 and later (LEIT Key not included).
- LEIT Key: Programming tool required to enter and program the controller (uses 1, 9-volt alkaline battery).
- Mounting column: model MCO4000 (short) 32" (81 cm) or MCO4000L (long) 48" (124 cm) steel pipe including mounting tool kit (1 screw, 1 spacing bolt, 1 hex-key 3/16").
- Actuator with in-line valve: each solenoid actuator comes complete with in-line valve (160HE-075 for 3/4", 100 for 1", 150 for 1-1/2" and 200 for 2").
For drip systems, use a drip zone assembly model P52-075 that includes a 160HE-075 3/4" valve, 155 mesh screen filter and 30 PSI preset pressure regulator.
- LEMA actuator only: (1600HE) one for each valve being used (see available adapters for mounting on any brand name valves).
- 7-solenoid adapters are available to fit most valves:
 - Model 30-920 use with BERMAD 200, HIT 500 and DOROT series 80, GRISWOLD 2000 and DW, BUCKNER VB series
 - Model 30-921, use with RAIN BIRD DV, DVF, PGA, PEB (3/4" and 1" only), GB, EFB-CP, BPE, PESB (3/4" and 1" only) and ASVF series
 - Model 30-922, use with HUNTER ASV, HPV, ICV, PGV, SRV, IBV and AS VF series
 - Model 30-923, use with WEATHERMATIC 12000 and 21000 series
 - Model 30-924, use with IRRITROL 100, 200B, 205, 217B, 700, 2400, 2500, 2600 series, TORO 220, P220
 - Model 30-925, use with SUPERIOR 950, HUNTER HBV, TORO 252 (1.5" and larger)
 - Model 30-926, use with RAINBIRD 1 1/2" and 2" PEB and PESB series

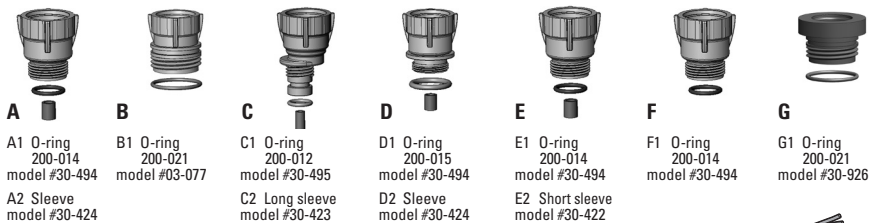
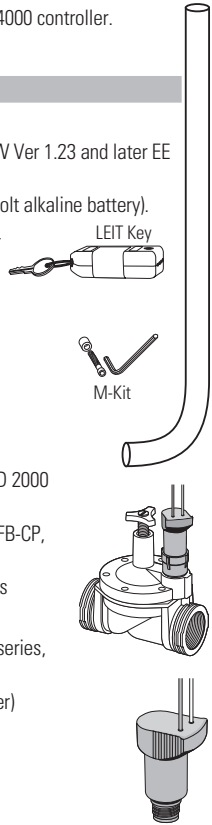

- Optional: Model SKIT 8821-4 connector: if any sensors are used, an SKIT 8821-4 adapter is required.
- Optional: Model RKIT 8810S relay: if pumps or any electrical equipment are used, an RKIT 8810S adapter is required.

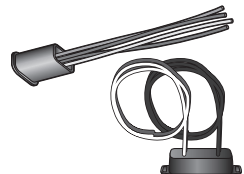

1.5 Tools and Supply Requirement

1. Battery: 9-volt alkaline battery for the LEIT Key
2. Standard wire stripper
3. Flathead screwdriver (9/64" or smaller)
4. Concrete: approximately three 60 lb (27 kg) bags
5. Conventional waterproof wire connectors

2. INSTALLATION

Select the optimum location for the LEIT 4000 controller. If possible locate the controller in open area not adjacent to a wall or building. We recommend installing a rain sensor with each controller with the use of adapter model SKIT 8821-4.

2.1 Valve Installation Model 160HE-XXX (2-WAY)

Recommended version is a complete valve assembly including LEMA solenoid actuator with plastic in-line valve (globe), sizes from 3/4" to 2".

Maximum static operating pressure is up to 150 PSI.

1. Shut off the mainline to the valve.
2. Install series 160HE-xxx valves with a solenoid actuator according to a valve standard installation specification (see Figure A on page 7).
3. After installation is completed, turn the water supply on and pressurize the mainline. The valves will open momentarily and then shut off. Test each valve in manual operation by moving the holder/handle from left to right to open and right to left to close the valve, making sure that the valve is operating correctly. The valve should open momentarily and then shut off.
4. Splice the solenoid actuator hot wires (red) to one of the color-coded wires. Splice the solenoid actuator white wire to the single incoming white (common) wire. Use 2 conventional dry-splice waterproof connectors. Leave the wires slightly loose on each side so that repairs, if needed, can be carried out easily. Make sure not to exceed the maximum run recommendation of wire distance (see page 7).

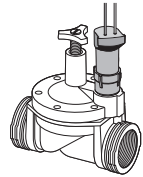

2.2 LEMA Solenoid Actuator Installation Model 1600HE (2-WAY)

Select the appropriate adapter for the valve(s) that will be used (see list on page 5).

The LEMA solenoid actuator operates only with 2-way normally closed valves.

Maximum static operating pressure is up to 150 PSI.

1. Shut off the mainline to the valve.
2. Unscrew the conventional solenoid from the valve and remove the solenoid housing, solenoid stem, plunger, spring, and O-ring (if necessary).
3. Select the appropriate conversion adapters for the valve(s) then thread and tighten the conversion adapter clockwise to the compatible valve port, do not over tighten.
4. Make sure that the solenoid holder/handle is not inserted into the solenoid housing, and then, screw the LEMA 1600HE assembly into the correct adapter. Firmly tighten the solenoid by hand, but do not over tighten.
5. Slip the LEMA 1600HE sleeve/handle into the solenoid housing. Positioning the solenoid handle at a 40-45° angle towards the valve creates a manual lever; helpful for manual on/off.
6. After installation is completed, turn the water supply on and pressurize the mainline. The valves will open momentarily and then shut off. Test each valve in manual operation by moving the holder/handle from left to right to open and right to left to close the valve, making sure that the valve is operating correctly. The valve should open momentarily and then shut off. If the valve remains open in manual operation, examine the adapter and the sleeve to see that it is installed correctly and the adapter is firmly secured. Do not over tighten the LEMA solenoid actuator to the valve and do not cross thread the adapter into the solenoid cavity

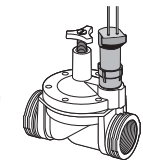
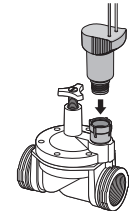
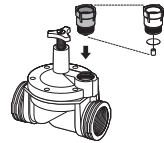

NOTE: For all brand name valves with internal manual bleed lever, make sure the lever is in closed position. Do not move the lever after installing the solenoid with the valve adapter. If the manual lever on the valve is used, it can damage the adapter or the sleeve causing the valve to stay open.

- Splice the solenoid actuator hot wires (red) to one of the color-coded field wires. Splice the solenoid actuator white wire to the incoming white (common) wire. Use 2 conventional **DRY-SPLICE WATERPROOF CONNECTORS**. Leave the wires slightly loose on each side so that repairs, if needed, can be carried out easily. Make sure not to exceed the maximum run recommendation of the wire distance (see A1 below).

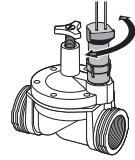

WARNING: The LEMA solenoid actuators must not be tested with any AC valve tester or DC tester over 9-volts. If you do so, it will cause irreparable damage to the LEMA solenoid actuator and the controller unit. Testing the solenoids with equipment rated higher than 9-volts will void the warranty.

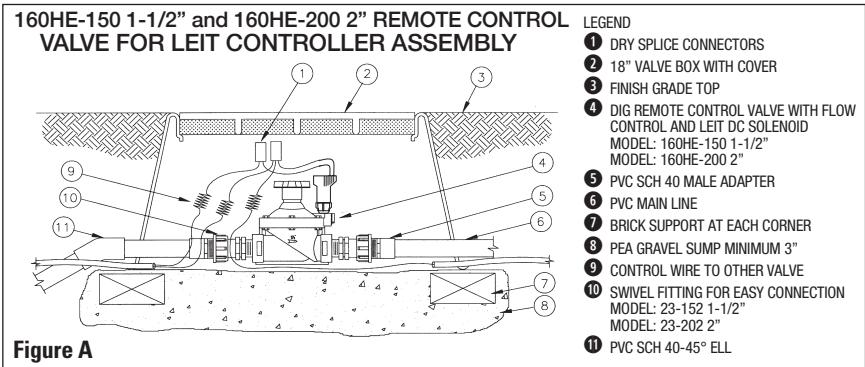

2.3 Wire Installation and Distance

Run all direct burial wires along their respective trenches from each valve box to the controller location. Use selection of color-coded direct burial wires to connect to each solenoid red (hot) wire. Use white (common) wire to connect to the solenoid's white (common) wire. Make sure to label each color-coded wire inside the irrigation box with the designated station number.

MAXIMUM WIRE DISTANCE		
Wire gauge recommendation	LEMA 1500S SOLENOIDS	LEMA 1600 HE SOLENOIDS
14 AWG (2.5 mm ²)	1500 feet (300 m)	4,500 feet (1365 m)
12 AWG (4 mm ²)	2400 feet (700 m)	7,500 feet (2272 m)

2.4 Controller Installation

- To install the mounting column, set the curved bottom of the mounting column in a 12" x 12" x 12" (30 x 30 x 30 cm) frame and pour in the three 60 lb (27 kg) bags of cement (see Figure A). Make sure the column is vertical and the opening in the curved bottom is accessible and unclogged. All wires should route to the controller through the bottom of the mounting column (see A1).

NOTE: Make sure the cement pad is dry before continuing with the installation.

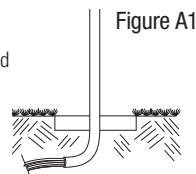

2. Run the field wires along their respective trenches from the valve box up to the bottom end of the mounting column. Make sure not to exceed the maximum recommended wire distance (see chart for maximum wire distance above). Push the wires up through the column until at least 12" (30 cm) of wire extends from the top of the mounting column (see B1).
3. Remove the door from the LEIT controller using the door key (included) and slide the controller into place on top of the mounting column. Make sure that 12" (30 cm) of wires are now inside the controller and cannot slip back down into the column (see C1).
4. Insert the clamp spacer and the screw (included with the mounting column) into the hole located on the lower left end of the controller. Tighten the screw with the hex-key (included) until the controller does not turn or twist and cannot be pulled off of the mounting column (see D1).
5. Connect the station wires to the controller using a standard wire stripper. Strip 3/10" of insulation from the tip of each of the station colored (labeled) wires. Connect the color-coded (hot) wires into the connector strip labeled with the station number and tighten the connector screw using a screwdriver. Connect the white (common) wire into either of the two common wire connectors labeled "common" located at the lower part of the connector strip and tighten the connector screw using a screwdriver. If using a master valve, connect the hot wire from the master valve into the station labeled "MV/P" (see Figure E1). For pump or other electrical equipment, see detailed installations on page 10.

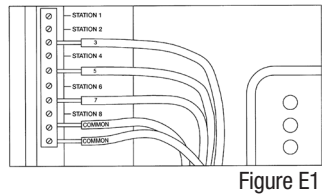
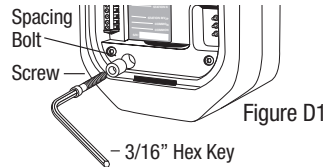
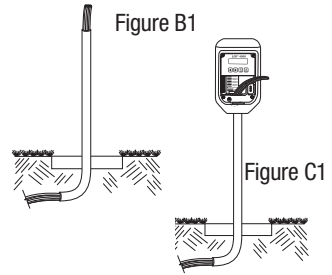

3. SENSOR INSTALLATION

The SKIT switch-type, weatherproof sensor adapter provides a quick, reliable way to connect a compatible rain, freeze, moisture or other normally closed, switch-type sensor. The connection can be made either directly to the LEIT series irrigation controllers or to one of the micro-powered solenoid actuators.

3.1 Sensor connection to unused station

If there is an unused station on the LEIT controller, connect the sensor directly using a SKIT 8821-4.

- a. Run a red (hot) wire from the unused station connector position on the LEIT controller to the red (hot) wire on the SKIT 8821-4. Then run a white (common) wire from the common connector station position on the LEIT controller to the white (common) wire on the SKIT. Finally, splice the two SKIT black wires to the sensor's two normally closed (N/C) wires (see Figure B, Option 1).

3.2 Sensor connection if station is not available

If station is unavailable, or the controller is too far from the sensor, connect the SKIT 8821-4 to LEMA actuators at a valve closest to the desired sensor location. This method can be used to minimize excessive wire runs (see Figure B, Option 2).

- b. Choose a valve that is closest to the sensor location. On the installed LEMA series actuator, splice the red (hot) wire to the SKIT's red (hot) wire AND to the red (hot) field wire creating a 3-wire connection. Next, splice the LEMA's white (common) wire to the SKIT's white (common) wire and connect both onto the common field wire. Again, a 3-wire connection should have been created. Finally, splice the two SKIT black wires to the sensor's two normally closed (N/C) wires.

3.3 Sensors compatible with LEIT controllers

Rain sensors are the HUNTER MINI-CLI[®]K and the RAIN BIRD RSD.

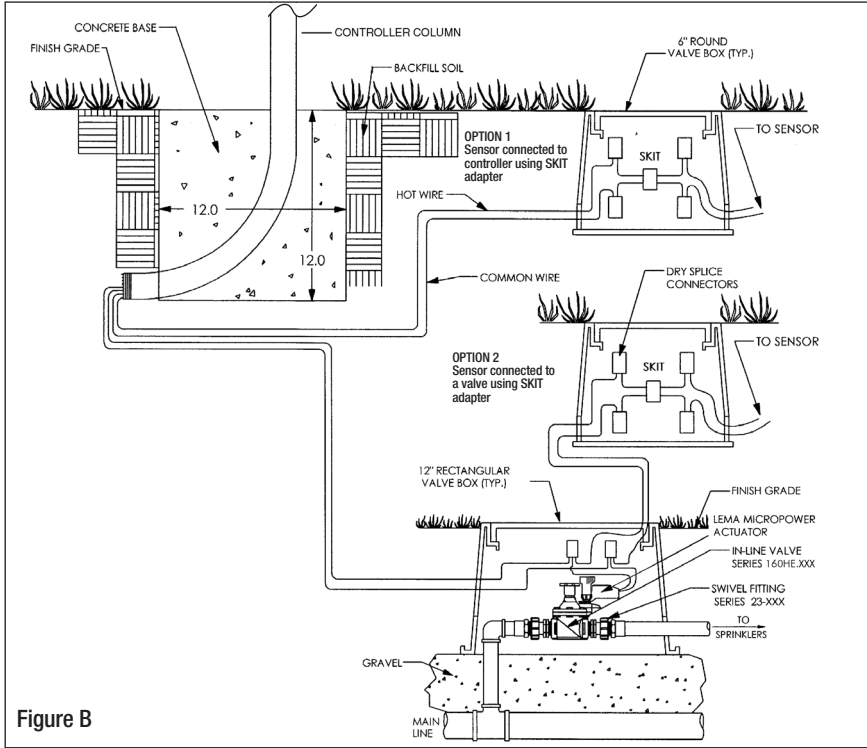

Moisture sensors are the IRROMETER, and WEM-B (battery).

Freeze sensor is the HUNTER FREEZE-CLI[®]K or RAINCLI[™]K RFC (rain-freeze combo).

NOTE: Wireless sensors are not compatible with LEIT controllers.

4. PUMP OR ANY ELECTRICAL EQUIPMENT INSTALLATION

If it is required to switch ON a pump, fertilizer injector, fountain or light, two connection options are available using the RKIT 8810S relay interface module.

The RKIT 8810S units are used to switch 10 amp electrical circuits to a voltage up to 250V AC or 30V DC.

NOTE: RKIT 8810S can be used with LEIT Series 4000, X and XRC.

4.1 RKIT Installation to the MV/Pump Terminal

To operate all the valves with the unit connected to (e.g. pump), connect the RKIT to the MV/Pump terminal (see Figure C).

4.2 RKIT Installation to One of the Valve Station Terminal Connectors

Operate only the valve number that RKIT has been installed to (e.g. Fountain will turn on/off by only the station that is using the RKIT).

To install the RKIT, run a red (hot) wire from the RKIT to any of the controller station terminals. Then, run a white (common) wire from the RKIT to the common terminal connector or if not available, splice it to the common field wire using a **WATERPROOF CONNECTOR**. Run the two black wires from the RKIT to the AC/DC equipment and connect them to the corresponding circuit to be switched (e.g. pump start relay).

Make sure to use **WATERPROOF DRY-SPLICE CONNECTORS** for all connections.

ELECTRICAL EQUIPMENT RELAY INTERFACE CONNECTION

LEGEND

1. FINISH GRADE
2. 6" ROUND VALVE BOX
3. RKIT ADAPTER PART NO. 8810-S. USE WITH EACH SENSOR
4. RED WIRE TO THE MV/PUMP TERMINAL OR ANY STATION TERMINAL
5. WHITE WIRE TO THE COMMON TERMINAL
6. DRY SPLICE CONNECTORS (4)
7. TO AC/DC EQUIPMENT OR PUMP START RELAY

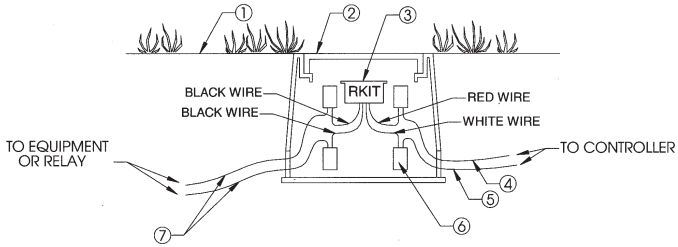

Figure C

NOTE: If the RKIT is connected to any circuit higher than 24-volts, it must be located in its own high voltage junction box in accordance with local electrical code.

If a pump start relay coil current is greater than 2A (Model 8810S 2A up to August 2007) or 10A (Model 8810S 10A after August 2007) use a pilot rotary.

WARNING: RKIT cannot be housed in the same box with any low voltage equipment. Do not connect the RKIT to a circuit higher than 380 VAC, 125 VDC.

CONTROLLER INSTALLATION

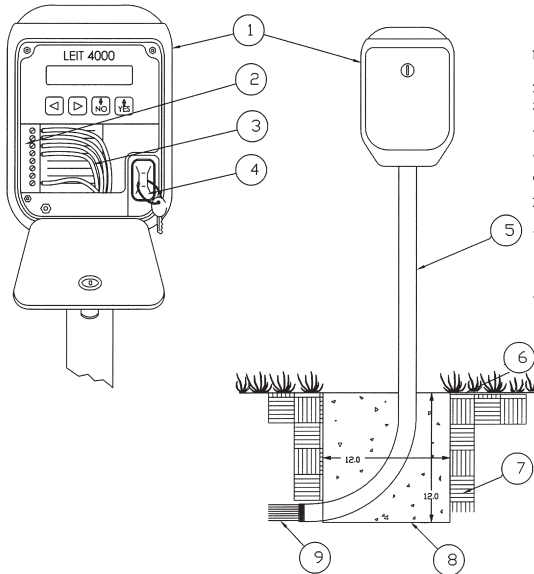

LEGEND

1. AMBIENT LIGHT POWERED IRRIGATION CONTROLLER.
2. TERMINAL STRIP.
3. 12 OR 14 GAUGE WIRE.
4. PROGRAMMING KEY.
5. 35" STEEL MOUNTING COLUMN.
6. FINISH GRADE.
7. 6-1/2" OF BACKFILL SOIL.
8. POURED CONCRETE BASE- 1-1/2 CU.FT. INSTALL PER MANUFACTURER'S INSTALLATION GUIDE.
9. DIRECT BURIAL CONTROL WIRES TO CONTROL VALVES.

1 LIGHT ENERGIZED IRRIGATION CONTROLLER
LEIT 4000

SENSOR INSTALLATION

LEGEND

- 1 "MINI CLIK" RAIN SENSOR.
- 2 DIG PLASTIC PIPE CAP - 1" CAP PART NO. 23-001 OR 1.5" CAP PART NO. 23-153 WITH HOLE FOR WIRES.
- 3 DRILL TWO 3/16 HOLES IN PIPE FOR SENSOR BRACKET.
- 4 (2) #8-32 MACHINE SCREWS WITH WASHER, LOCK WASHER AND NUT.
- 5 1" OR 1.5" GALVANIZED PIPE 6 TO 10 FEET HIGH.
- 6 12"x12" CONCRETE BASE 8" DEEP MINIMUM.
- 7 1" OR 1.5" PIPE ELBOW.
- 8 FINISH GRADE.
- 9 6" ROUND VALVE BOX.
- 10 PART NO. SKIT ADAPTER 8821-4 USE WITH EACH SENSOR.
- 11 TO CONTROLLER OR VALVE.
- 12 (4) DRY SPlice CONNECTORS.
- 13 NORMALLY CLOSED WIRE FROM SENSOR.
- 14 COMMON WIRE FROM SENSOR.
- 15 1" OR 1.5" NIPPLE.
- 16 GRAVEL.

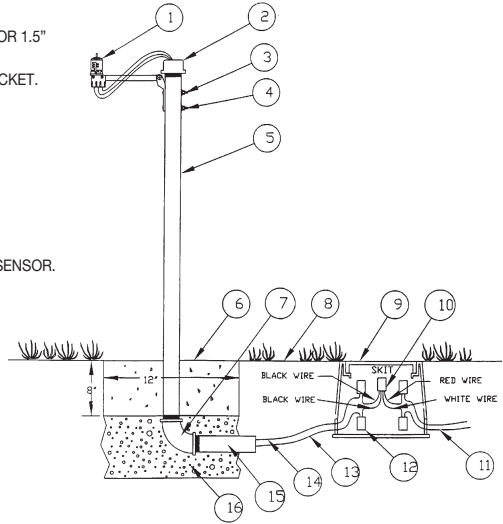

2 RAIN SENSOR ASSEMBLY COLUMN MOUNTED

VALVE INSTALLATION

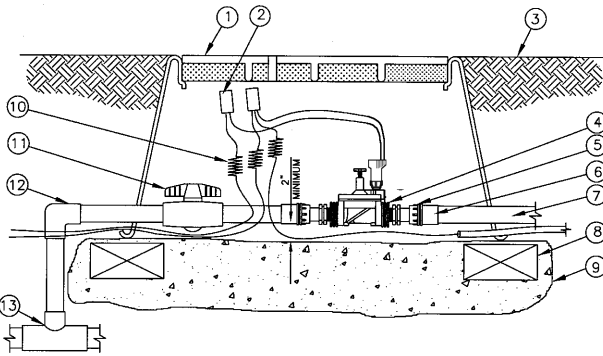

- 1 VALVE BOX WITH COVER 18" SIZE.
- 2 DRY SPlice WATERPROOF CONNECTORS
- 3 FINISH GRADE TOP.
- 4 DIG VALVE MODEL 3/4" 160HE-075 1" 160HE-100
- 5 SWIVEL FITTING DIG MODEL 3/4" 23-004, 1" 23-003.
- 6 PVC SCH 40 MALE ADAPTER.
- 7 PVC LATERAL LINE.
- 8 BRICK SUPPORT AT EACH CORNER.
- 9 PEA GRAVEL SUMP - MINIMUM 3".
- 10 12 OR 14 GAUGE WIRE.
- 11 BACK-UP NPT PVC BALL VALVE.
- 12 PVC SCH 40 90 DEGREE ELL.
- 13 SCH 40 TEE.

160HE-075 3/4" AND 160HE-100 1" REMOTE CONTROL VALVE

3 160HE-075 3/4 AND 160HE-100 1" REMOTE CONTROL VALVE ASSEMBLY

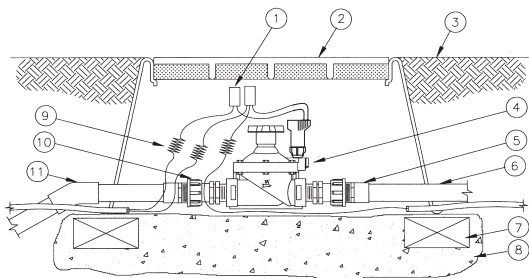

LEGEND

- 1 DRY SPLICE WATERPROOF CONNECTORS
- 2 18" VALVE BOX WITH COVER
- 3 FINISH GRADE TOP
- 4 DIG REMOTE CONTROL VALVE WITH FLOW CONTROL AND LEIT DC SOLENOID
MODEL: 160HE-150 1-1/2"
MODEL: 160HE-200 2"
- 5 PVC SCH 40 MALE ADAPTER
- 6 PVC MAIN LINE
- 7 BRICK SUPPORT AT EACH CORNER
- 8 PEA GRAVEL SUMP MINIMUM 3"
- 9 CONTROL WIRE FOR EASY CONNECTION
- 10 SWIVEL FITTING FOR EASY CONNECTION
MODEL: 23-152 1-1/2"
MODEL: 23-202 2"
- 11 PVC SCH 40-45° ELL

4 160HE-150 1-1/2" and 160HE-200 2" REMOTE CONTROL VALVE FOR LEIT CONTROLLER ASSEMBLY

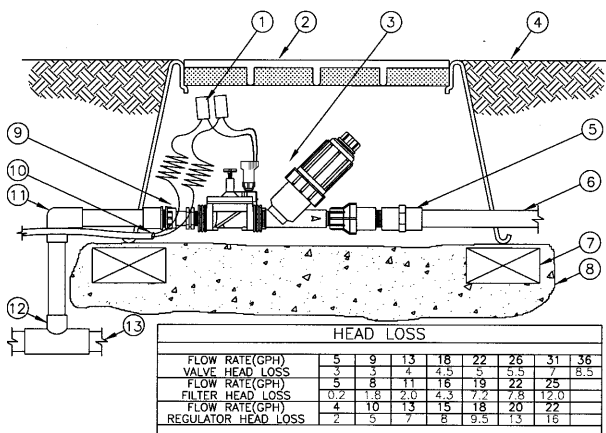

- 1 WIRE CONNECTORS
- 2 VALVE BOX WITH COVER
12" SIZE
- 3 DIG LEIT 3/4" REMOTE CONTROL VALVE ASSEMBLY
MODEL P52-075
- 4 FINISH GRADE TOP
- 5 3/4" FEMALE NPT COUPLING x SLIP
- 6 PVC LATERAL LINE
- 7 BRICK SUPPORT AT EACH CORNER
- 8 PEA GRAVEL SUMP
MINIMUM 3"
- 9 SWIVEL FITTING DIG MODEL
23-004 1" F X 3/4" M
- 10 CONTROL WIRE TO OTHER VALVE
- 11 PVC SCH 40 90 DEGREE ELL
- 12 SCH 40 TEE
- 13 MAIN SUPPLY LINE

	HEAD LOSS							
FLOW RATE(GPH)	5	9	13	18	22	26	31	36
VALVE HEAD LOSS	3	3	4	4.5	5	5.5	7	8.5
FLOW RATE(GPH)	5	8	11	16	19	22	25	
FILTER HEAD LOSS	0.2	1.8	2.0	4.3	7.7	7.8	12.0	
FLOW RATE(GPH)	4	10	13	15	18	20	22	
REGULATOR HEAD LOSS	2	5	7	8	9.5	13	16	

5 P52-075 3/4" REMOTE CONTROL VALVE ASSEMBLY FOR A DRIP SYSTEM WITH A 155 MESH FILTER AND 30 PSI PRESET PRESSURE REGULATOR

5. PROGRAMMING

This chapter explains the controller buttons hierarchy and how to review, modify settings, program the controller, or perform a Manual Run. To enter the controller, the user needs a LEIT KEY. Insert the LEIT KEY into the controller key slot and follow the steps below. After the information on the screen comes to view, the user can select the language, then review, program, modify settings or perform a Manual Run. For the Programming Quick Reference, see section 8 or inside the door panel on the controller.

The controller is programmed with the aid of 4 buttons:

↑ YES Use to accept the desired programming mode, select a parameter and raise (increase) the value of the selected parameter.

↓ NO Use to deselect a parameter and lower (decrease) the value of the selected parameter.

◀ Use to move the cursor to left.

▶ Use to move the cursor to right.

To move between applications (left to right) use the right or left arrow buttons. To enter an application (Moving up) uses the YES button.

INSERT LEIT KEY INTO THE SOCKET IN THE UPPER LEFT CORNER OF THE CONTROLLER.

The above screens appear while the controller is charging.

NOTE: If the controller is being programmed for the first time under a low light level it may take up to 5 minutes to charge the controller using the LEIT Key.

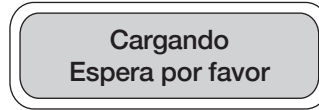
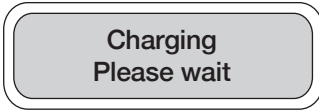

The below screens appear and alternate when the LEIT controller is fully charged. When the characters are most readable, press  to select the language to use and continue to the next screen.

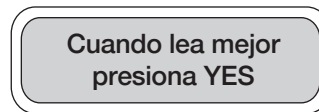
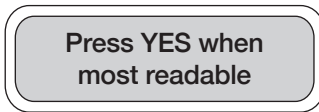

This screen identifies the controller model and the number of stations it has. Press  to continue.



This screen appears identifying the software versions that are installed in the controller. Press  to continue.

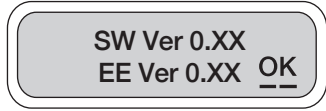

This screen appears with the date and time. If the controller is being programmed for the first time, it will not display the correct time and date. Update this screen in the next few steps.

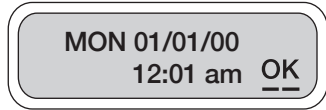

Press  to continue.

5.1 MANUAL RUN

Setting up a Manual Run.



The Manual Run is useful for checking the proper operation of stations (especially after installation), for applying additional water as required, or for testing the valves.

The first option available on the main menu is the Manual Run option.

The Manual Run feature allows one to test a selected valve, select a temporary program or run a stored program. Note that at the completion of Manual Run any programmed irrigation schedule is cancelled.

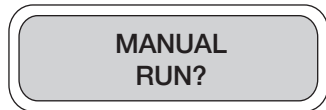
Manual Run feature overrides any sensor control, but not Budgeting.



Press  to select Manual Run or skip Manual Run and move to the next option by pressing  or .

You have the option to run any of the stored programs (assuming that they have been programmed) or to set up and run a temporary program. For example, to set a temporary program, underscore Temp by pressing

◀ or ▶ and select temp by pressing **↑ YES**, then press ◀ or ▶ button again and underscore OK, press **↑ YES** and the next screen will appear.

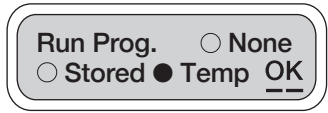

Press ◀ or ▶ to underscore the hour or minute digits, then press **↑ YES** or **↓ NO** to adjust the runtime. When finished, press ◀ or ▶ to underscore OK and press **↑ YES** to continue. Follow the same procedure for the remaining valves. To skip any valve, simply set the runtime to 0 and press **↑ YES** to continue. In this option you will need to pass through all the valve numbers.

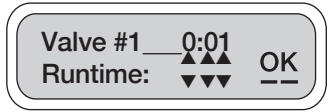

Press **↑ YES** to start the Manual Run, (if you are standing within the spray area, remove the LEIT Key, replace and lock the LEIT 4000 door to protect the controller and move out of the spray area).

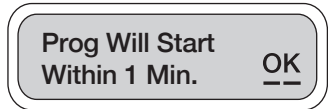

The LEIT 4000 will start the Manual Run in approximately one minute and will run each valve for the programmed duration.

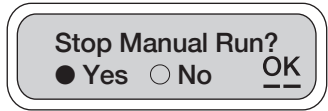

To STOP the Manual Run prematurely, re-insert the LEIT Key, press **↑ YES** until you see the Manual Run display. Press **↑ YES** again to view the "Stop Manual Run" screen.

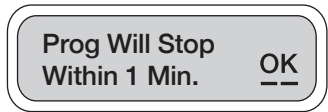

Select Yes by pressing ◀ or ▶ and press **↑ YES**, then underscore OK and press **↑ YES**, the following screen will appear.

Ok is underscored, press **↑ YES** and the Manual Run will stop within 60 seconds. The screen will return to the Manual Run menu.

Press ▶ to continue to the next step.

5.2 RAIN STOP/RESTART

Setting up a temporary suspension of all irrigation programs.

The Rain Stop feature is used to temporarily suspend all irrigation programs. For example, during rainy weather, regularly scheduled programs can be stopped for periods from 1-99 days. At the end of the designated period the regularly scheduled programming will resume automatically.



To enter Rain Stop/Restart press **↑ YES**. Press ▶ to skip Rain Stop and to move to the next feature.

The Password screen provides the user security against unauthorized changes being made to the system.

The Default password is AAA. If the password has not been changed press **↑ YES** to continue. If the password has been changed, enter the new password to continue.

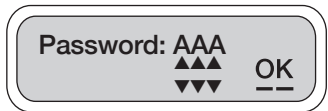

To enter the new password press ◀ or ▶ and underscore the digit to be changed, then press **↑ YES** or **↓ NO** to select the appropriate letter. Repeat the steps for each letter. When finished,

press or to underscore OK. Press **YES** to continue.

To implement a Rain Stop press or and underscore 0 days. Press **YES** or **NO** and enter the number of days needed to

suspend irrigation (from 1-99 days). Press or to underscore OK. Press **YES** to continue.

Rain Stop will cancel itself automatically at 12 AM on the last day of the programmed setting.

If Rain Stop is active it can be cancelled manually anytime in the Cancel Rain Stop screen. Once there, press

or to underscore Yes and press **YES** to select. Press or again to underscore OK. Press

YES to continue, this will bring back the Rain Stop screen.

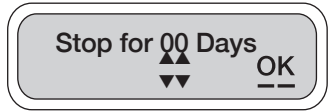

5.3 MONTHLY BUDGET

Instead of changing duration for each program, you can use the Monthly Budget feature to increase or decrease the amount of water used during seasonally dry or wet periods on a monthly basis. Budget adjustments can range from 10% to 200% of your set time in 10% increments. The LEIT 4000 will automatically adjust the programmed duration for each valve according to the entered Budget per month.

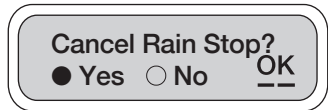

At this display, press **YES**.

Press the or button to underscore the percentage digits,

press the **YES** or **NO** to increase or decrease the percentage

(in increments of 10%). Then press the or button to

underscore OK and press **YES** to advance to the next month.



Repeat this procedure to enter the desired Budgets for the

remaining months. To skip a month, simply press **YES**. In this

procedure you will need to pass thru the 12 months to return to

Monthly Budget. You can enable or disable your stations to be budgeted in the Setup System menu (see page 17).

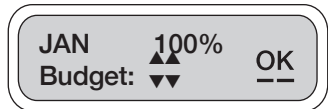

Press the to continue to the next step.

5.4 CHECK STATUS

This feature allows you to review the unit's time, date and sensor setup. Status also reports the current month's watering time totals for each station as well as those for the previous month.





1. Press **YES**.

Reports on current date and time of day.

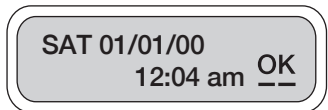
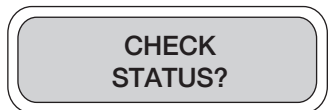
2. Press **YES** to review sensor setup.

Reports on sensors currently in use, if any.



3. Press  to review valve number current month uses.
Reports how much time was logged on each of your valves during the current month.
4. Press  to review the individual log for each valve. Press  after the last valve report to review the previous month log for each valve.
5. Reports how much time was logged on each valve during the previous month. Press  to review the individual log for each valve. Press  after the last valve report to return to the Check Status screen.

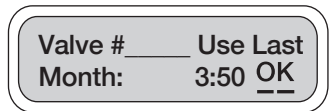
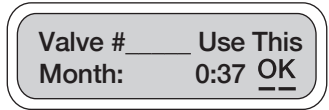
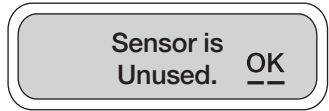



Press the  to continue to the next step.

5.5 SETUP SCHEDULE

This feature allows you to schedule up to four separate programs for each station, each with up to three individual start times per day.

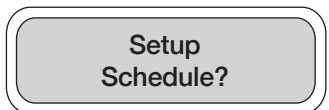
Press  to enter the password screen.





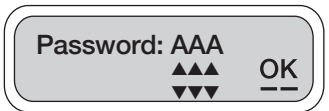

Passwords are provided to give the user security against unauthorized changes being made to the system. If you are programming the controller for the first time the default password is AAA. If you wish, you can customize your password in the System Setup. For now underscore OK and press  to go to the next step.







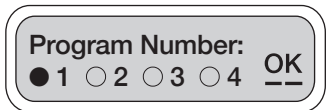

For example if the controller has been programmed with new password (ABC), to enter your password,

press  or  to underscore the first letter and press  or

 to select A. Repeat the step for each letter, then underscore OK by using  or  and press  to go to select a program number.



Program # 1 is a default program. To select additional programs underscore the program number by using  or  and press , then press  or  to underscore OK and press  again to select the program type in the next screen.

NOTE: Program will not run unless you activated the program number in the system setup.







Program type options include:

Every- lets you operate stations from once a day to once every 39 days.







Even- every even numbered day

Odd- every odd numbered day





MTWTFSS- lets you select specific day(s) of the week to irrigate.

Underscore the preferred option by using  or , then press . Repeat using  or  and underscore OK and press  again. If you select **MTWTFSS**, you'll get the following screen to select the day of the week:





Every Even
 MTWTFSS Odd OK

Choose one or more days you want the controller to operate by underscoring the appropriate box under the preferred day using  or  and press  to accept. The selected days will show a checkmark instead of the empty boxes. Repeat the steps again to select other days. Underscore OK by using the  or  and press  to go to Start Time.

Water MTWTFSS
Days: OK

First start time: You can select up to three start times a day (including AM or PM). To program the first start time underscore the appropriate digit using the  or  and press  or  to change the hour. Repeat the steps again to change minute or AM/PM. Repeat the steps to underscore OK and press  to go to the second start time.

1st Start 12:00 am
 ▲▲▲▲▲
 ▼▼▼▼▼ OK

If you wish to run a second start time, underscore Yes using  or  and press , then repeat the steps again and underscore OK and press  again to go to second start time set up.





2nd Start Time?
 Yes No OK

You may set a second and after that a third start time, by repeating the steps above. You can later cancel any of the additional start times simply by selecting No instead of Yes.

2nd Start 12:00 am
 ▲▲▲▲▲
 ▼▼▼▼▼ OK





Underscore OK and press  to enter duration for each valve.

Programming Runtime for each valve: (You can set a runtime from 1 minute to 5 hours and 59 min).

Underscore the appropriate digits using the  or  and press  or  to change the hour or minute. Repeat the steps and underscore OK and press  to go to valve # 2. Follow the same procedure for the remaining valves. To skip a valve, simply set the duration to zero.

Valve # 0:01
Runtime: ▲▲▲ OK
 ▼▼▼

Remember that the duration for each valve will be repeated with each of the three start times if selected.

Once you have completed program 1, you'll find yourself back in the Setup Schedule display. Press  if you want to repeat the setup procedure, to enter another program or press  or  to make corrections to the existing program OR press the  to continue to the next step.

5.6 SETUP SYSTEM



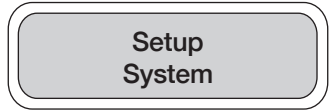

This part of the menu enables you to set the correct time and date, activate or de-activate programs, change passwords, etc.

Press  to enter SETUP SYSTEM.







Press  or enter the correct password if it has been customized. (This screen will NOT be displayed if you have already entered the password in the SETUP SCHEDULE menu.)







* If you have to enter a customized password, press the left arrow button to underscore the first digit then enter the first letter or number of the password using  or , scroll through the alphabet and numbers. When the correct letter or number has been selected, press  to jump to the next digit and repeat step for the second and third digit. When your password is shown correctly on the screen press  to underscore OK and press  to enter the new password setup and go to the next screen.





In Setup System if all the information on the screen is correct, you may skip any of the following screens by pressing .

To set the time, underscore the appropriate digits using  or  and press  or  to change the setting. When finished, underscore OK and press  to go to set the date.

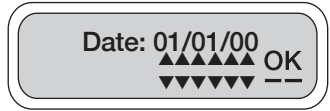

To set the date, underscore the appropriate digits using  or  and press  or  to change the setting. Repeat the steps as needed and when finished, underscore OK and press  to activate program.





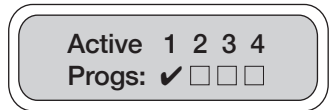

In this step, up to four independent programs can be activated. Number 1 is factory activated (checked). To enable the controller to activate or cancel any of the stored programs simply add or remove the check marks by underscoring the appropriate boxes using  or  and pressing . Repeat the steps as needed, underscore OK and press  to proceed to the valve options screen.











NOTE: Scheduled programs will not run unless you activated the appropriate program number in this screen.

This setting has two options for each valve.

Valve #1 Options:
 MV/P Budget **OK**







Option one, MV/P: if checked, the valve # will operate with an installed master valve or pump. To switch on an installed MV/P use  or  to underscore MV/P and press  to checkmark the box then underscore OK and press  to move to the next screen or...

Option two, Budget: if checked, the valve # will be affected by the monthly budget setting. All valves are budgeted by default, if you wish to deactivate the budget, repeat the steps to uncheck the marks under budget. Press  and underscore OK. Repeat the same procedure for the remaining valves then underscore OK and press  to move to the next screen.

This setup indicates whether or not a sensor is activated and in use: if you install a sensor, use  or  to underscore Yes and press the  button, then press  or  to underscore OK and press  to enter sensor location.







Sensor in Use?
 Yes No **OK**



This setup indicates a sensor location.







If you selected YES in the "Sensor in Use" screen, you must indicate which station will have the SKIT and sensor(s) connected to it. Press  or  to underscore MV/P or other, press  , then use  or  to underscore OK and press  again to go to next screen and specify which station the sensor(s) is/are connected.

Sensor Location:
 MV/P Other **OK**

* MV/P indicates that the sensor is connected to the master valve, "Other" indicates that the sensor is connected to one of your stations.





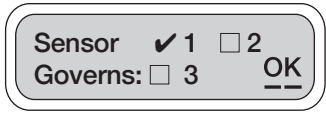

If you selected "Other" you must now specify which station number the sensor(s) is/are connected to. Press  or  to underscore the number and press  or  to enter the correct station #. Then press  or  to underscore OK and press  to go to sensor governing.

Sensor Location: 1
  **OK**





At this screen, you can set up any or all of the installed valves to be switched off when the sensor is triggered. Checkmark the boxes next to the station numbers that you wish to be governed by the sensor by using  or  and underscore the appropriate box, by pressing  to checkmark the box then underscore OK using  or  and press  to go to change password screen.



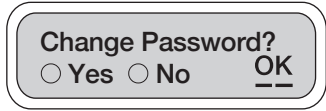



If an installed switch type sensor is triggered, any valve that is checkmarked and is currently “ON” will complete its programmed runtime. All further valve operations will be prevented until the sensor deactivates and allows watering again.

You may change the default password (AAA) to any three-digit combination of letters or numbers. Just underscore Yes, using  or , then press the  to underscore OK using  or  and press  to enter your new password screen.

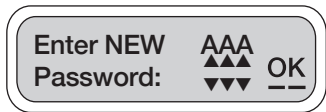

Enter your new password: Press  or  to underscore the digits you want to change, use  or  buttons to change the password. When finished, write down the password so as not to forget it.



Underscore OK using  or  and press  to exit. This will bring you back to the Setup System screen. Press  to QUIT the programming session.



Remember that any person who makes changes to the watering schedule or the setup, needs to enter the new password.

If you're ready to quit programming, press  and remove the LEIT KEY.



If the above screens have been completed successfully, your LEIT 4000 is now fully operational 24 hours a day!

6. TROUBLESHOOTING

The LEIT irrigation control system is a series of connected components consisting of an ambient light powered controller, LEIT Key, LEMA actuators, hydraulic control valves, and field wires/splices. It is best to troubleshoot this DC system (like an AC system) by a process of elimination; the goal being to determine which component(s) has failed. The following facts and tips may be helpful to eliminate certain components and facilitate faster troubleshooting. It is assumed that these are installed controllers that are receiving the proper amount of light. Keep in mind that the problem may be with more than one component.

6.1 LEIT Key

1. Use only name brand, alkaline, 9-volt batteries.
2. Weak batteries in a good LEIT Key will result in no display, a "CHARGING PLEASE WAIT" message, or a partial or blinking display.
3. If the LEIT Key works in one LEIT controller but not another, the key is functioning and the problem is with the controller.
4. If in doubt about the battery, install a new battery, or test the key with a multi-meter by holding the probes into the metal holes, voltage should be at least 8-volts DC.
5. The LEIT Key will work with all current and discontinued SOLATROL, ALTEC, and current LEIT controllers.

6.2 LEIT Controllers

1. If a "good" LEIT Key is inserted into a controller and there is no display, the problem is with the controller.
2. When a "good" LEIT Key is installed in a LEIT controller, "PRESS YES WHEN MOST READABLE" (English or Spanish) should appear on the display immediately.
3. If a LEIT Key is installed and the display reads "CHARGING PLEASE WAIT" the controller probably has a problem with the PVM.
4. If the LEIT controller is not holding the current day/time, the problem is with the controller.
5. If the display is scrambled or showing unrecognizable characters, first install a new battery in the LEIT Key.
6. If one or more of the keypad buttons are sticky or non-functional, the problem is with the controller.
7. To test a controller's output, connect a "good" LEMA 1600HE or 1500 actuator directly to the terminal strip, and initiate a temporary Manual Run with 1 minute to the station in question and zero minutes on all other stations. Verify that the plunger retracts and extends or you hear the sound of the plunger latching inside the solenoid. If it does not retract or make any sound, the problem is with the controller.
8. ALTEC Dash 4 or LEMA 1600 actuators cannot be used on expansion controllers.
9. If the controller functions properly doing a temporary Manual Run, but is not running valves automatically by program, the controller is probably incorrectly programmed. In SETUP SYSTEM check active programs, sensor & MV/P settings. In SETUP SCHEDULE, make sure no programs overlap.
10. LEIT controllers will only function with LEMA actuators.
11. Compatible rain sensors are the HUNTER MINI-CLIK or RAIN BIRD RSD. The SKIT 8821-4 sensor adapter must be used with any sensor.

6.3 LEMA Solenoid Actuators

1. Verify that the proper model number, solenoid actuator and series is being used for the controller in question.
2. Verify that the white wire is connected to the common wire, and the red wire is connected to the "hot" wire, and that these splices are tight, and corrosion free.
3. Verify that no water is leaking near the adapter, stem or bonnet.
4. Verify that all O-rings and/or rubber sleeves are in place. If in doubt, check manuals.
 - a. To test a LEMA actuator, remove the actuator from the valve and disconnect the hot and common wires. Verify the actuator functions with a 9-volt battery by holding the wires to the positive and negative contacts. Reverse polarity if nothing happens. Plunger should retract. Reverse polarity to close, (plunger should extend).
 - b. If a LEMA actuator does not function with a 9-volt battery, the problem is with the actuator, and it should be replaced.

NOTE: Never use a high power source, such as a car battery to test a LEMA 1500 or 1600 solenoid actuator. If a 9-volt battery is used, never connect the solenoid for a long period, just briefly touch the wire. If applying power for more than half second, it can destroy the solenoid actuator.

5. If the LEMA actuator works with the battery but not through the controller, remove the solenoid actuator from the valve and connect the LEMA actuator directly to the controller terminal strip and institute a temporary Manual Run. If it functions, the problem is with the field wires or the hydraulic valve.
6. If the valve is weeping or not closing completely the adapter may be loose, cross-threaded, missing an O-ring, the adapter sleeve is damaged, or the valve diaphragm could be in need of cleaning or replacement.
7. If the valve is not opening completely, the adapter being used may be too tight, the adapter sleeve may be damaged, or the valve water passage down stream may be plugged and in need of cleaning.

The LEMA solenoid actuator operates only with 2-way normally closed valves.

8. Solenoid parts list shown to the right.

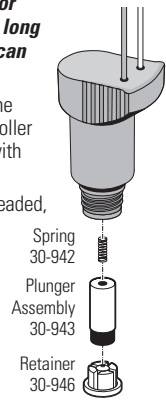

6.4 Hydraulic Valves

1. Verify that the valve opens and closes with the manual bleed. If it does not, the problem is with the valve (valve repair should be done by others).
 - a. Verify that the static mainline pressure at the valve is below 150 PSI and above 10 PSI.
 - b. Verify that the valve size is correct for the flow rate of the system.
 - c. LEMA actuators should be installed only on normally closed 2-way valves (check catalog or web-site for compatible models).

For all brand name valves with internal manual bleed lever, make sure the lever is in closed position. Do not move the lever after installing the solenoid with the valve adapter. If the manual lever on the valve is used, it can damage the adapter or the sleeve causing the valve to stay open.

6.5 Field Control Wires

1. Verify that the proper actuator series are being used for the controller in question.
2. Verify that the common wire (usually white) is connected to the common terminal and that the wire screw is tight.
3. Verify that all hot wires are in the proper terminals and the screws are tight.
4. Verify that all common and hot wire splices at the valves and splice boxes are tight and made with waterproof connectors.
5. 12 and 14 AWG direct burial single strand solid core irrigation wires are recommended, 18 AWG multi-strands are not.
6. Sometimes it may be prudent to run temporary wires above grade to the valve to verify a problem with the wire.
7. Wire problems are not the responsibility of DIG Corp.
8. If the same color hot wires are run to all valves, the wires should be identified and tagged with numbered stickers.

7. WARRANTY

DIG Corp. warrants to its customers who have purchased LEIT products, from an authorized DIG distributor, that its products will be free from original defects in material and workmanship for a period of four (4) years, from the date of original purchase. If any apparent defect arises under normal use and service in the LEIT product within the warranty period, DIG at its sole discretion, shall have the option to repair or replace part or all of the original product free of charge after return of such product at user expense, authorized in writing by DIG Corp. If a product is replaced, the replacement product will be covered for the remainder of the warranty period dating from the original purchase.

This warranty applies only to the DIG LEIT product line, which are installed as specified and used for irrigation purposes. This warranty applies only to products, which have not been altered, modified, damaged, misused or misapplied. This warranty does not cover products adversely affected by the system into which the products are incorporated, including improperly designed, installed, operated, or maintained systems. This warranty does not apply to blockage of solenoids due to use of water containing corrosive chemicals, electrolytes, sand, dirt, silt, rust, scale, algae, bacterial slime or other organic contaminants.

Tampering with a product (including, but not limited to attempting to disassemble) will void any warranty the product might otherwise be eligible for. In no event shall DIG's liability exceed the selling price of the product. DIG is not liable for consequential, incidental, indirect or special damages, including but not limited to the labor to inspect, remove or replace products, vegetation loss, loss of energy or water, cost of substitute equipment or services, property damage, loss of use or loss of profits; nor is DIG liable for economic losses, consequential damages or damage to property arising out of installer's negligence or based on strict liability in tort. The user and/or trade customer agrees to the limitations and exclusions of liability of this warranty by purchase or use of DIG products.

No representative, agent, distributor or other person has the authority to waive, alter, or add to the printed provisions of this warranty, or to make any representation of warranty not contained here.

Some states do not permit the exclusion or limitation of incidental or consequential damages or of implied warranties. Therefore, some of the above exclusions or limitations may not apply to you.

This warranty on LEIT products is given expressly and in place of all other expressed or implied warranties of merchantability and fitness for particular purpose, and this warranty is the only warranty on LEIT products line made by DIG Corp.

8. LEIT CONTROL PROGRAMMING QUICK REFERENCE CHART

LEIT® 4000 Programming Quick Reference

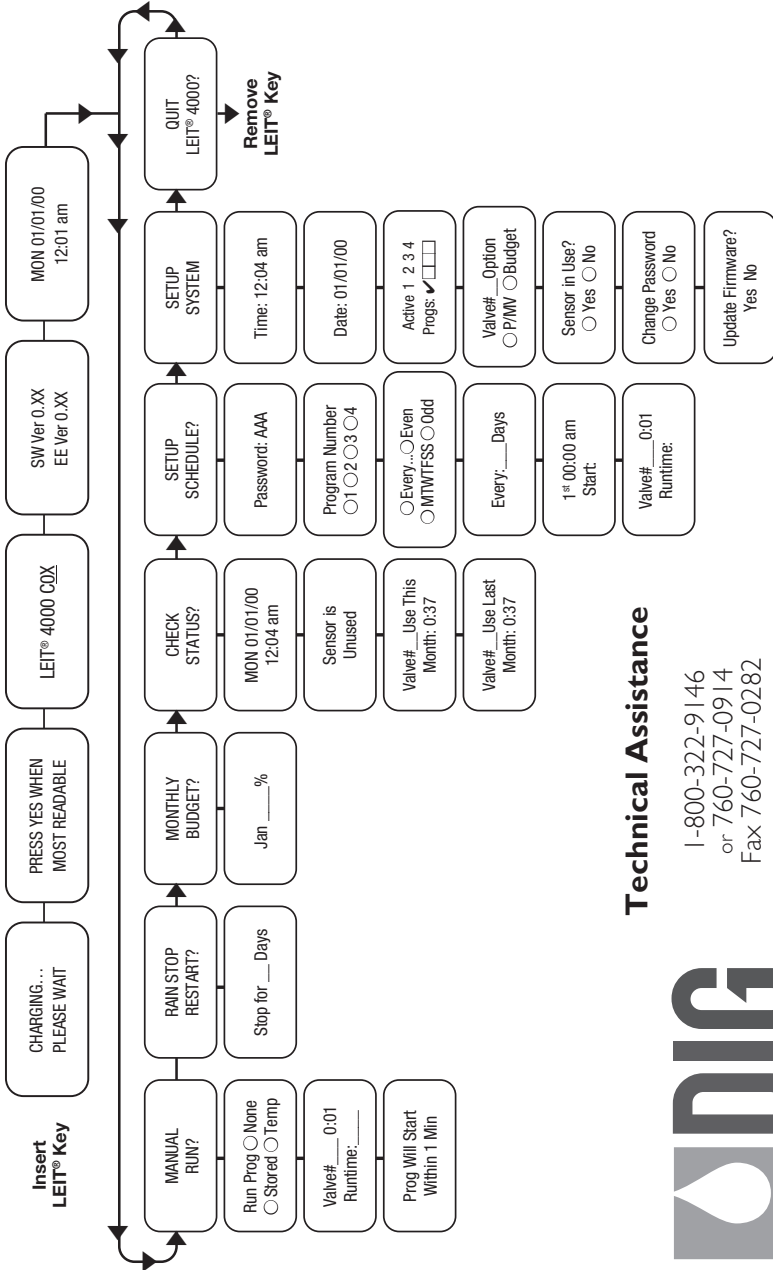

Technical Assistance



1-800-322-9146
or 760-727-0914
Fax 760-727-0282
Email: dig@digcorp.com
www.digcorp.com

9. LEIT 4000 USB UPDATER

The LEIT 4000 is now supplied with a convenient USB port in order for your controller to be kept up to date with new software versions.



Before attempting to update to the most recent software version on your LEIT controller, first check to see if your controller has the current software installed. Visit the link: www.digcorp.com/LEIT-4000-software-update to see the current version. Next check your controllers software version by inserting the LEIT key into the controller then press Yes until you get to the software version screen:

SW Ver X.XX
EE Ver X.XX

If the software version differs from what is online, then an update is available.

***This update requires a standard USB cable with a type A and type B connectors (not included).**

Supported operating systems:

- Windows 7
- Windows XP
- Windows Vista
- Windows 2000

*At this time Apple OSX is not supported.

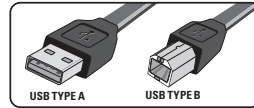

- Step 1** Open your browser (i.e. Internet Explorer, Firefox, Chrome, etc) and type in the address www.digcorp.com/LEIT-4000-software-update and download the LEIT-4000-USB-Update-XXX.zip file.
- Step 2** After the file has completed downloading, unzip it.
- Step 3** If this is the first time this computer will be used to update the LEIT 4000 you must also download the LEIT-4000-USB-Drivers.zip file and install the drivers. If the drivers have previously been installed on this computer then skip to Step 6.
- Step 4** After the drivers file has completed downloading, unzip it.
- Step 5** Open up the unzipped LEIT-4000-USB-Drivers folder.
1. For Windows 2000 computers, double-click to run the LEIT 4000 USB Drivers W2K.exe file.
 2. For all other supported version of Windows, double-click to run the LEIT 4000 USB Drivers.exe file.
- IMPORTANT NOTE: you must have Administrator privileges to install the new drivers on your computer.
3. For Windows 7 computers, right click on the LEIT 4000 USB Drivers.exe file and select Run as Administrator.
- Step 6** Open up the unzipped LEIT-4000-USB-Update-XXX folder and double-click to run the LEIT 4000 USB Update XXX.exe file, where the new version XXX is the version to be installed. If you have any questions please call us at 1-800-322-9146 or 760-727-0914.

Step 7 Follow all instructions on screen to complete the update process of your LEIT 4000 controller (see Figure A). After the update process is complete, disconnect the USB cable (see Figure B).

Note: If the LEIT 4000 is installed, use a laptop to update the controller in the field.

FIGURE A

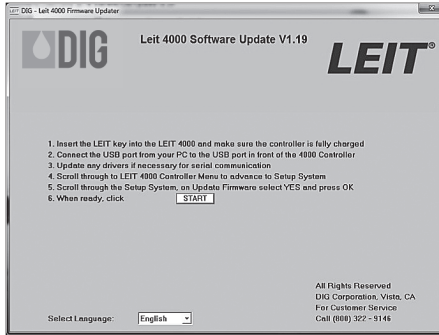
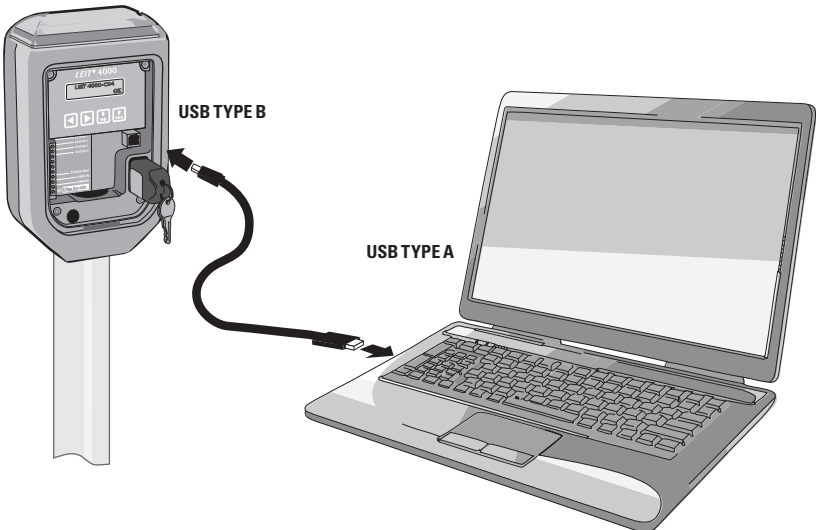
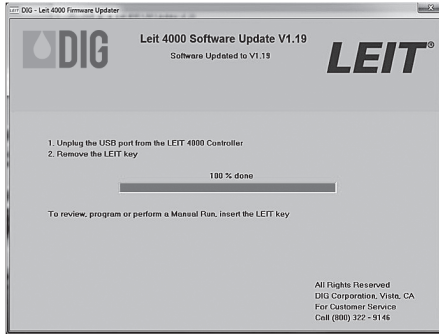

FIGURE B





1210 Activity Drive
Vista, CA 92081-8510, USA

www.digcorp.com
email: dig@digcorp.com
26-400 REVA 050216
Printed in the USA

